

## Description

---

The Modular Power System II supplies 5 VDC, 15 VDC, -15 VDC, 24 VDC, 48 VDC, and 125 VDC power to Harmony components of the Symphony Enterprise Management and Control System. The power system provides the operating voltages to Harmony I/O blocks, and Harmony rack I/O, controller, and communications modules as well as power to operate field devices. The power system accepts 120 VAC, 240 VAC, or 125 VDC input power.

The Modular Power System II consists of the following components:

- Chassis:
  - IPCHS01 Power Module Chassis (supports Harmony rack modules only).
  - IPCHS02 Power Module Chassis (supports both Harmony blocks and rack modules).
  - IPFCH01 Power Fan Chassis.
- Power entry:
  - IPECB11 Power Entry Circuit Breaker (AC).
  - IPECB13 Power Entry Circuit Breaker (DC).
  - IPESW11 Power Entry Switch (AC).
  - IPESW13 Power Entry Switch (DC).
- Modules:
  - IPBLC01 Harmony Power (24 VDC).
  - IPFLD01 Field Power (24 VDC).
  - IPFLD24 Field Power (24 VDC).
  - IPFLD48 Field Power (48 VDC).
  - IPFLD125 Field Power (125 VDC).
  - IPMON01 Power Monitor Module.
  - IPSYS01 System Power (5 VDC, 15 VDC, -15 VDC, 24 VDC).
- System fans:
  - IPFAN11 Power System Fan (120 VAC).
  - IPFAN12 Power System Fan (240 VAC).
  - IPFAN13 Power System Fan (125 VDC).

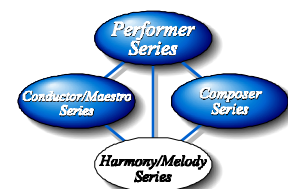

## Power Module Usage by System

Power Module	Harmony Block I/O	Harmony Rack I/O
IPBLC01	•	
IPFLD01		•
IPFLD24	•	•
IPFLD48	•	•
IPFLD125	•	•
IPSYS01		•

## Related Documents

Number	Document Title
WBPEEUS210505?0	Harmony Modular Power System II, Overview

## Specifications

Property	Characteristic/Value												
<b>General</b>													
Power input Voltage	<table border="1"> <thead> <tr> <th rowspan="2">External Ambient Temp.</th> <th colspan="2">Input Voltage</th> </tr> <tr> <th>Nominal</th> <th>Operating Range</th> </tr> </thead> <tbody> <tr> <td rowspan="3">0° to 55°C (32° to 131°F)</td> <td>120 VAC</td> <td>102 to 132 VAC</td> </tr> <tr> <td>240 VAC</td> <td>204 to 264 VAC</td> </tr> <tr> <td>125 VDC</td> <td>102 to 144 VDC</td> </tr> </tbody> </table>	External Ambient Temp.	Input Voltage		Nominal	Operating Range	0° to 55°C (32° to 131°F)	120 VAC	102 to 132 VAC	240 VAC	204 to 264 VAC	125 VDC	102 to 144 VDC
External Ambient Temp.	Input Voltage												
	Nominal	Operating Range											
0° to 55°C (32° to 131°F)	120 VAC	102 to 132 VAC											
	240 VAC	204 to 264 VAC											
	125 VDC	102 to 144 VDC											
Current	20 A maximum per side												
Peak inrush current	15 A per power module for 100 msecs maximum for AC or DC input power												
Frequency	47 to 63 Hz												
Total harmonic distortion	Less than 5%												
Efficiency	60% at full rated load												
Power factor	Actively corrected to 0.95 minimum at input currents greater than 0.5 A												
Power module chassis	IPCHS01, IPCHS02												
Input power capacity	20 A maximum per side												
Output bus capacity	85 A at 5.1 VDC maximum 15 A at ±15.1 VDC maximum 85 A at 25.5 VDC maximum 12 A at 49.1 VDC maximum 12 A at 125.6 VDC maximum												
IPCHS02 Harmony power connector rating	Approximately 7 A												
Power entry circuit breaker	IPECB11, IPECB13												

Property	Characteristic/Value																																																																											
Power entry switch Input voltage IPECB11, IPEWS11 IPECB13, IPEWS13 Input current Voltage drop across breaker/ switch	IPEWS11, IPEWS13  102 to 264 VAC 102 to 144 VDC 20 A maximum 2 V drop at 20 A nominal																																																																											
System fans Input power IPFAN11 IPFAN12 IPFAN13 Frequency	IPFAN11, IPFAN12, IPFAN13  0.6 A nominal at 120 VAC 0.4 A nominal at 240 VAC 0.7 A nominal at 125 VDC 47 to 63 Hz																																																																											
Weight and dimensions	<table border="1"> <thead> <tr> <th>Module<sup>1</sup></th> <th>Weight kg (lb)</th> <th>Height mm (in.)</th> <th>Width mm (in.)</th> <th>Depth<sup>2</sup> mm (in.)</th> </tr> </thead> <tbody> <tr> <td>IPBLC01</td> <td>2.49 (5.46)</td> <td>218.40 (8.60)</td> <td>48.30 (1.90)</td> <td>440.50 (17.50)</td> </tr> <tr> <td>IPBLK01</td> <td>0.89 (1.95)</td> <td>218.40 (8.60)</td> <td>48.30 (1.90)</td> <td>444.50 (17.50)</td> </tr> <tr> <td>IPFLD01</td> <td>2.36 (5.20)</td> <td>218.40 (8.60)</td> <td>48.30 (1.90)</td> <td>444.50 (17.50)</td> </tr> <tr> <td>IPFLD24</td> <td>2.49 (5.46)</td> <td>218.40 (8.60)</td> <td>48.30 (1.90)</td> <td>444.50 (17.50)</td> </tr> <tr> <td>IPFLD48</td> <td>2.55 (5.62)</td> <td>218.40 (8.60)</td> <td>48.30 (1.90)</td> <td>444.50 (17.50)</td> </tr> <tr> <td>IPFLD125</td> <td>2.55 (5.62)</td> <td>218.40 (8.60)</td> <td>48.30 (1.90)</td> <td>444.50 (17.50)</td> </tr> <tr> <td>IPMON01</td> <td>0.71 (1.56)</td> <td>218.40 (8.60)</td> <td>35.56 (1.40)</td> <td>401.32 (15.80)</td> </tr> <tr> <td>IPSYS01</td> <td>2.55 (5.60)</td> <td>218.40 (8.60)</td> <td>48.30 (1.90)</td> <td>444.50 (17.50)</td> </tr> </tbody> </table> <p><b>NOTES:</b> 1. The total system weight is 48 kg (106 lb) maximum. 2. Dimension includes the handle.</p> <table border="1"> <thead> <tr> <th>Component<sup>1</sup></th> <th>Weight kg (lb)</th> <th>Height mm (in.)</th> <th>Width mm (in.)</th> <th>Depth mm (in.)</th> </tr> </thead> <tbody> <tr> <td>IPCHS01/02</td> <td>7.55 (16.60)</td> <td>223.50 (8.80)</td> <td>482.60 (19.00)</td> <td>444.50 (17.50)</td> </tr> <tr> <td>IPECB11/13</td> <td>2.55 (5.60)</td> <td>114.30 (4.50)</td> <td>193.04 (7.60)</td> <td>162.56 (6.40)</td> </tr> <tr> <td>IPESW11/13</td> <td>2.55 (5.60)</td> <td>114.30 (4.50)</td> <td>193.04 (7.60)</td> <td>162.56 (6.40)</td> </tr> <tr> <td>IPFAN11/12/13</td> <td>3.23 (7.10)</td> <td>152.40 (6.00)</td> <td>210.82 (8.30)</td> <td>444.50 (17.50)</td> </tr> <tr> <td>IPFCH01</td> <td>10.20 (22.40)</td> <td>203.20 (8.00)</td> <td>482.60 (19.00)</td> <td>472.44 (18.60)</td> </tr> </tbody> </table> <p><b>NOTE:</b> 1. The total system weight is 48 kg (106 lb) maximum.</p>	Module <sup>1</sup>	Weight kg (lb)	Height mm (in.)	Width mm (in.)	Depth <sup>2</sup> mm (in.)	IPBLC01	2.49 (5.46)	218.40 (8.60)	48.30 (1.90)	440.50 (17.50)	IPBLK01	0.89 (1.95)	218.40 (8.60)	48.30 (1.90)	444.50 (17.50)	IPFLD01	2.36 (5.20)	218.40 (8.60)	48.30 (1.90)	444.50 (17.50)	IPFLD24	2.49 (5.46)	218.40 (8.60)	48.30 (1.90)	444.50 (17.50)	IPFLD48	2.55 (5.62)	218.40 (8.60)	48.30 (1.90)	444.50 (17.50)	IPFLD125	2.55 (5.62)	218.40 (8.60)	48.30 (1.90)	444.50 (17.50)	IPMON01	0.71 (1.56)	218.40 (8.60)	35.56 (1.40)	401.32 (15.80)	IPSYS01	2.55 (5.60)	218.40 (8.60)	48.30 (1.90)	444.50 (17.50)	Component <sup>1</sup>	Weight kg (lb)	Height mm (in.)	Width mm (in.)	Depth mm (in.)	IPCHS01/02	7.55 (16.60)	223.50 (8.80)	482.60 (19.00)	444.50 (17.50)	IPECB11/13	2.55 (5.60)	114.30 (4.50)	193.04 (7.60)	162.56 (6.40)	IPESW11/13	2.55 (5.60)	114.30 (4.50)	193.04 (7.60)	162.56 (6.40)	IPFAN11/12/13	3.23 (7.10)	152.40 (6.00)	210.82 (8.30)	444.50 (17.50)	IPFCH01	10.20 (22.40)	203.20 (8.00)	482.60 (19.00)	472.44 (18.60)
Module <sup>1</sup>	Weight kg (lb)	Height mm (in.)	Width mm (in.)	Depth <sup>2</sup> mm (in.)																																																																								
IPBLC01	2.49 (5.46)	218.40 (8.60)	48.30 (1.90)	440.50 (17.50)																																																																								
IPBLK01	0.89 (1.95)	218.40 (8.60)	48.30 (1.90)	444.50 (17.50)																																																																								
IPFLD01	2.36 (5.20)	218.40 (8.60)	48.30 (1.90)	444.50 (17.50)																																																																								
IPFLD24	2.49 (5.46)	218.40 (8.60)	48.30 (1.90)	444.50 (17.50)																																																																								
IPFLD48	2.55 (5.62)	218.40 (8.60)	48.30 (1.90)	444.50 (17.50)																																																																								
IPFLD125	2.55 (5.62)	218.40 (8.60)	48.30 (1.90)	444.50 (17.50)																																																																								
IPMON01	0.71 (1.56)	218.40 (8.60)	35.56 (1.40)	401.32 (15.80)																																																																								
IPSYS01	2.55 (5.60)	218.40 (8.60)	48.30 (1.90)	444.50 (17.50)																																																																								
Component <sup>1</sup>	Weight kg (lb)	Height mm (in.)	Width mm (in.)	Depth mm (in.)																																																																								
IPCHS01/02	7.55 (16.60)	223.50 (8.80)	482.60 (19.00)	444.50 (17.50)																																																																								
IPECB11/13	2.55 (5.60)	114.30 (4.50)	193.04 (7.60)	162.56 (6.40)																																																																								
IPESW11/13	2.55 (5.60)	114.30 (4.50)	193.04 (7.60)	162.56 (6.40)																																																																								
IPFAN11/12/13	3.23 (7.10)	152.40 (6.00)	210.82 (8.30)	444.50 (17.50)																																																																								
IPFCH01	10.20 (22.40)	203.20 (8.00)	482.60 (19.00)	472.44 (18.60)																																																																								
Electromagnetic/radio frequency interference	Meets IEC 801.3, level 3, 80 MHz to 1 GHz with no loss of function or false status information for all units.  <b>NOTE:</b> Do not use RFI sources producing 10 V/m or greater at 84.9 MHz within 2.2 m (7.2 ft) of the MPS II system.																																																																											
Fast transient/burst susceptibility	Meets IEC 801.4, level 3, mains 2 kV at 2.5 kHz, outputs 1 kV at 5.0 kHz with no loss of function or false status information.																																																																											
Transient surge	Meets IEC 801.5, level 3, 2 kV with no loss of function or false status information.																																																																											

Property	Characteristic/Value																																																				
Electrostatic discharge	Meets IEC 801.2, level 3 with no loss of function or false status information.																																																				
Environmental																																																					
Temperature																																																					
Operating enclosure (internal)	0° to 70°C (32° to 158°F)																																																				
Operating enclosure (external)	0° to 55°C (32° to 131°F)																																																				
Storage and transport	(-40° to 85°C (-40° to 185°F)																																																				
Relative humidity																																																					
Operating	20% to 90% up to 55°C (131°F) noncondensing 20% to 45% at 55° to 70°C (131° to 158°F) noncondensing																																																				
Altitude																																																					
Operating	Sea level to 3,048 m (10,000 ft)																																																				
Storage and transport	Up to 9,144 m (30,000 ft)																																																				
Air quality	Noncorrosive per ISA S71.04 class LA, LB, LC severity level 1																																																				
Overvoltage category	IEC 1010-1 Category III, for mains Category II, for mains to the IPCHS01 and IPCHS02 chassis Category I, for outputs																																																				
Vibration	13.2 to 100 Hz, 0.7 Gs 2 to 13.2 Hz, 12 mm (0.47 in.) peak-to-peak displacement																																																				
Certifications																																																					
Canadian Standards Association (CSA)	Certified for use as process control equipment in an ordinary (nonhazardous) location.																																																				
Factory Mutual (FM)	Approval for the following categories: Nonincendive for Class I Division 2, Groups A,B,C,D																																																				
<b>IPBLC01, IPFLD01, IPFLD24, IPFLD48, IPFLD125, IPSYS01</b>																																																					
Power input																																																					
Voltage	102 to 264 VAC; 102 to 144 VDC																																																				
Current	<table border="1"> <thead> <tr> <th rowspan="2">Module</th> <th colspan="3">Full Load Input Current (A)</th> </tr> <tr> <th>120 VAC</th> <th>240 VAC</th> <th>125 VDC</th> </tr> </thead> <tbody> <tr> <td>IPBLC01</td> <td>4.7</td> <td>2.4</td> <td>4.7</td> </tr> <tr> <td>IPFLD01</td> <td>2.2</td> <td>1.0</td> <td>2.2</td> </tr> <tr> <td>IPFLD24</td> <td>4.7</td> <td>2.4</td> <td>4.7</td> </tr> <tr> <td>IPFLD48</td> <td>4.4</td> <td>2.2</td> <td>4.4</td> </tr> <tr> <td>IPFLD125</td> <td>4.7</td> <td>2.4</td> <td>4.7</td> </tr> <tr> <td>IPSYS01</td> <td>4.3</td> <td>2.0</td> <td>4.3</td> </tr> </tbody> </table>	Module	Full Load Input Current (A)			120 VAC	240 VAC	125 VDC	IPBLC01	4.7	2.4	4.7	IPFLD01	2.2	1.0	2.2	IPFLD24	4.7	2.4	4.7	IPFLD48	4.4	2.2	4.4	IPFLD125	4.7	2.4	4.7	IPSYS01	4.3	2.0	4.3																					
Module	Full Load Input Current (A)																																																				
	120 VAC	240 VAC	125 VDC																																																		
IPBLC01	4.7	2.4	4.7																																																		
IPFLD01	2.2	1.0	2.2																																																		
IPFLD24	4.7	2.4	4.7																																																		
IPFLD48	4.4	2.2	4.4																																																		
IPFLD125	4.7	2.4	4.7																																																		
IPSYS01	4.3	2.0	4.3																																																		
Power output																																																					
Voltage/current	<table border="1"> <thead> <tr> <th rowspan="2">Module Outputs</th> <th colspan="4">IPSYS01<sup>1</sup></th> <th rowspan="2">IPBLC01 IPFLD01 IPFLD24</th> <th rowspan="2">IPFLD48</th> <th rowspan="2">IPFLD125</th> </tr> <tr> <th>5.09</th> <th>15.10</th> <th>-15.10</th> <th>25.50</th> </tr> </thead> <tbody> <tr> <td>Nominal VDC</td> <td>5.09</td> <td>15.10</td> <td>-15.10</td> <td>25.50</td> <td>25.50</td> <td>49.1</td> <td>125.6</td> </tr> <tr> <td>Minimum VDC</td> <td>5.04</td> <td>14.95</td> <td>-14.95</td> <td>24.35</td> <td>24.35</td> <td>48.5</td> <td>124.2</td> </tr> <tr> <td>Maximum VDC</td> <td>5.25</td> <td>15.75</td> <td>-15.75</td> <td>26.80</td> <td>26.80</td> <td>49.6</td> <td>127.1</td> </tr> <tr> <td>Maximum ripple and noise (mV<sub>pp</sub>)</td> <td>100</td> <td>150</td> <td>150</td> <td>250</td> <td>250</td> <td>600</td> <td>1,000</td> </tr> <tr> <td>Full load (A)</td> <td>17.00</td> <td>1.80</td> <td>1.80</td> <td>5.60</td> <td>5.60/11.2<sup>2</sup></td> <td>5.45</td> <td>2.3</td> </tr> </tbody> </table> <p><b>NOTES:</b> 1. Total module power output cannot exceed 260 W. 2. 11.2 A for IPBLC01 and IPFLD24 modules.</p>	Module Outputs	IPSYS01 <sup>1</sup>				IPBLC01 IPFLD01 IPFLD24	IPFLD48	IPFLD125	5.09	15.10	-15.10	25.50	Nominal VDC	5.09	15.10	-15.10	25.50	25.50	49.1	125.6	Minimum VDC	5.04	14.95	-14.95	24.35	24.35	48.5	124.2	Maximum VDC	5.25	15.75	-15.75	26.80	26.80	49.6	127.1	Maximum ripple and noise (mV <sub>pp</sub> )	100	150	150	250	250	600	1,000	Full load (A)	17.00	1.80	1.80	5.60	5.60/11.2 <sup>2</sup>	5.45	2.3
Module Outputs	IPSYS01 <sup>1</sup>				IPBLC01 IPFLD01 IPFLD24	IPFLD48				IPFLD125																																											
	5.09	15.10	-15.10	25.50																																																	
Nominal VDC	5.09	15.10	-15.10	25.50	25.50	49.1	125.6																																														
Minimum VDC	5.04	14.95	-14.95	24.35	24.35	48.5	124.2																																														
Maximum VDC	5.25	15.75	-15.75	26.80	26.80	49.6	127.1																																														
Maximum ripple and noise (mV <sub>pp</sub> )	100	150	150	250	250	600	1,000																																														
Full load (A)	17.00	1.80	1.80	5.60	5.60/11.2 <sup>2</sup>	5.45	2.3																																														

Property	Characteristic/Value																																												
Load sharing	Current shared equally between modules within 5% (highest current load to lowest current load) at full load																																												
Line regulation	$\pm 0.5\%$ of the nominal output voltage over the input voltage range																																												
Load regulation	Within specified minimum and maximum outputs from 0% to 100% load																																												
Hold up time	20 msec following loss of power																																												
Heat dissipation	190 W (IPBLC01, IPFLD24, IPFLD48, IPFLD125) 95 W (IPFLD01) 175 W (IPSYS01)																																												
<b>IPMON01</b>																																													
Power input	0.3 A at 120 VAC 0.2 A at 240 VAC and 125 VDC																																												
System bus voltage monitor trip points	<table border="1"> <thead> <tr> <th rowspan="2">Voltage Bus Nominal (VDC)</th> <th colspan="2">Low Trip</th> <th colspan="2">High Trip</th> </tr> <tr> <th>Min</th> <th>Max</th> <th>Min</th> <th>Max</th> </tr> </thead> <tbody> <tr> <td>5</td> <td>4.75</td> <td>4.80</td> <td>NA<sup>1</sup></td> <td>NA<sup>1</sup></td> </tr> <tr> <td>15</td> <td>14.50</td> <td>14.70</td> <td>NA<sup>1</sup></td> <td>NA<sup>1</sup></td> </tr> <tr> <td>-15</td> <td>-14.50</td> <td>-14.70</td> <td>NA<sup>1</sup></td> <td>NA<sup>1</sup></td> </tr> <tr> <td>25.5</td> <td>24.20</td> <td>24.50</td> <td>NA<sup>1</sup></td> <td>NA<sup>1</sup></td> </tr> <tr> <td>25.5 (aux)</td> <td>21.40</td> <td>21.60</td> <td>27.00</td> <td>27.40</td> </tr> <tr> <td>49.1 (aux)</td> <td>42.50</td> <td>43.35</td> <td>54.00</td> <td>54.60</td> </tr> <tr> <td>125.6 (aux)</td> <td>113.05</td> <td>115.05</td> <td>142.75</td> <td>144.75</td> </tr> </tbody> </table> <p><b>NOTE:</b> 1. Power module provides overvoltage protection.</p>	Voltage Bus Nominal (VDC)	Low Trip		High Trip		Min	Max	Min	Max	5	4.75	4.80	NA <sup>1</sup>	NA <sup>1</sup>	15	14.50	14.70	NA <sup>1</sup>	NA <sup>1</sup>	-15	-14.50	-14.70	NA <sup>1</sup>	NA <sup>1</sup>	25.5	24.20	24.50	NA <sup>1</sup>	NA <sup>1</sup>	25.5 (aux)	21.40	21.60	27.00	27.40	49.1 (aux)	42.50	43.35	54.00	54.60	125.6 (aux)	113.05	115.05	142.75	144.75
Voltage Bus Nominal (VDC)	Low Trip		High Trip																																										
	Min	Max	Min	Max																																									
5	4.75	4.80	NA <sup>1</sup>	NA <sup>1</sup>																																									
15	14.50	14.70	NA <sup>1</sup>	NA <sup>1</sup>																																									
-15	-14.50	-14.70	NA <sup>1</sup>	NA <sup>1</sup>																																									
25.5	24.20	24.50	NA <sup>1</sup>	NA <sup>1</sup>																																									
25.5 (aux)	21.40	21.60	27.00	27.40																																									
49.1 (aux)	42.50	43.35	54.00	54.60																																									
125.6 (aux)	113.05	115.05	142.75	144.75																																									
Input voltage monitor trip points	<table border="1"> <thead> <tr> <th rowspan="2">Input Voltage (Nominal)</th> <th colspan="2">Low Trip<sup>1</sup></th> </tr> <tr> <th>Min</th> <th>Max</th> </tr> </thead> <tbody> <tr> <td>120 VAC</td> <td>88</td> <td>90</td> </tr> <tr> <td>240 VAC</td> <td>176</td> <td>180</td> </tr> <tr> <td>125 VDC</td> <td>88</td> <td>90</td> </tr> </tbody> </table> <p><b>NOTE:</b> 1. The MPS II system will operate at voltages as low as the input voltage monitor low trip point, however operation below the minimum system input voltage specification is not recommended.</p>	Input Voltage (Nominal)	Low Trip <sup>1</sup>		Min	Max	120 VAC	88	90	240 VAC	176	180	125 VDC	88	90																														
Input Voltage (Nominal)	Low Trip <sup>1</sup>																																												
	Min	Max																																											
120 VAC	88	90																																											
240 VAC	176	180																																											
125 VDC	88	90																																											
Logic status inputs	2 inputs, logic 0 = fault Logic 0 $\leq$ 0.8 VDC at 10 mA sink current Logic 1 $\geq$ 3.1VDC at 80 $\mu$ A source current																																												
Fan status inputs	2 inputs for fan speed monitoring of low fan speed (fan speed controlled as a function on internal cabinet temperature)																																												
Power fail interrupt (PFI)	1 output, open collector driven (nonisolated), logic 0 = power failure Logic 0 $\leq$ 0.8 VDC at 10 mA sink current Logic 1 $\geq$ 4.75 to 5.25 VDC at 80 $\mu$ A source current																																												
Status out	1 output, open collector driven (nonisolated), logic 0 = fault Logic 0 $\leq$ 0.8 VDC at 10 mA sink current Logic 1 $\geq$ 4.75 to 5.25 VDC at 80 $\mu$ A source current																																												
Bus alarm	1 output, opto-isolated open collector driven (24 V), logic 1 = fault Logic 0 $\leq$ 1.2 VDC at 150 mA sink current Logic 1 $\geq$ 5 to 30 VDC at 80 $\mu$ A source current																																												

Property	Characteristic/Value
Power alarm	1 output, opto-isolated open collector driven (24 V), logic 1 = fault Logic 0 $\leq$ 1.2 VDC at 150 mA sink current Logic 1 $\geq$ 5 to 30 VDC at 80 $\mu$ A source current
I/O alarm	1 output, opto-isolated open collector driven (24 V), logic 1 = fault Logic 0 $\leq$ 1.2 VDC at 150 mA sink current Logic 1 $\geq$ 5 to 30 VDC at 80 $\mu$ A source current

SPECIFICATIONS SUBJECT TO CHANGE WITHOUT NOTICE

## Nomenclature

1	2	3	4	5	6	7	8	
								<b>Chassis</b>
I	P	C	H	S	0	1	_	Power module chassis (supports Harmony rack modules only)
I	P	C	H	S	0	2	_	Power module chassis (supports both Harmony blocks and rack modules)
I	P	F	C	H	0	1	_	Power fan chassis
								<b>Fans</b>
I	P	F	A	N	1	1	_	120 VAC
I	P	F	A	N	1	2	_	240 VAC
I	P	F	A	N	1	3	_	125 VDC
								<b>Modules</b>
I	P	B	L	C	0	1	_	Harmony power (24 VDC)
I	P	F	L	D	0	1	_	Field power (24 VDC)
I	P	F	L	D	2	4	_	Field power (24 VDC)
I	P	F	L	D	4	8	_	Field power (48 VDC)
I	P	F	L	D	1	2	5	Field power (125 VDC)
I	P	M	O	N	0	1	_	Power monitor
I	P	S	Y	S	0	1	_	System power (5 VDC, 15 VDC, -15 VDC, 24 VDC)
								<b>Power Entry</b>
I	P	E	C	B	1	1	_	Circuit breaker (AC)
I	P	E	C	B	1	3	_	Circuit breaker (DC)
I	P	E	S	W	1	1	_	Switch (AC)
I	P	E	S	W	1	3	_	Switch (DC)



*Visit Elsag Bailey on the World Wide Web at <http://www.ebpa.com>*

---

Our worldwide staff of professionals is ready to meet *your* needs for process automation.  
For the location nearest you, please contact the appropriate regional office.

**AMERICAS**

29801 Euclid Avenue  
Wickliffe, Ohio USA 44092  
Telephone 1-440-585-8500  
Telefax 1-440-585-8756

**ASIA/PACIFIC**

539 Yishun Industrial Park A  
Singapore 768740  
Telephone 65-756-7655  
Telefax 65-753-6549

**GERMANY**

Industriestrasse 28  
D-65760 Eschborn  
Germany  
Telephone 49-6196-800-0  
Telefax 49-6196-800-1119

**EUROPE, AFRICA, MIDDLE EAST**

Via Puccini 2  
16154 Genoa, Italy  
Telephone 39-10-6584-943  
Telefax 39-10-6584-941

## Features and Benefits

- **Versatile:** Supplies operating voltages to both Harmony block and rack equipment.
- **Availability:** Selectable N, N+1, N+x, and 2N power supply redundancy.
- **High output capacity:** 260 watts output per module means fewer power modules are needed.
- **Active load sharing:** Insures all power modules share load equally.
- **Inputs:** 120/240 VAC or 125 VDC with mixed AC and DC inputs in 2N redundancy.
- **Input power factor correction:** Lowers upstream investments such as electrical distribution and uninterrupted power supply (UPS).
- **Power monitoring:** Monitors AC and DC power inputs, system I/O and bus voltages, cabinet temperatures, and auxiliary channel and contact inputs.
- **On-line replaceable:** Power supply modules and fans are replaceable while the system is operating.



ICU0894A

The power architecture of the Harmony Modular Power System II is designed to be flexible so that it can be easily adapted to the needs of the application.

When two power sources are utilized the Modular Power System II can be split into two sections with four power module slots per section. This *2N split architecture* offers the highest level of power availability. Each section supplies only 50 percent of the load under normal conditions but is capable of supplying 100 percent of the load under a failure condition. The low stress at 50 percent of capacity assures a long life time.

When only one power source is used to supply *secure* power to the Modular Power System II, the two sections of the split architecture are strapped together providing *N+x power architecture*. Each power module is supplied from one source and shares the load equally.

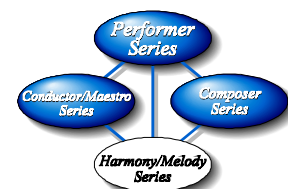

# Overview

The Modular Power System II supplies 5 VDC, 15 VDC, -15 VDC, 24 VDC, 48 VDC, and 125 VDC power to Harmony components of the Symphony Enterprise Management and Control System. Figure 1 shows the power system architecture. The power system provides the operating voltages for Harmony devices such as Harmony I/O blocks, and Harmony rack I/O, rack controller, and rack communications modules. It also provides power to operate field devices.

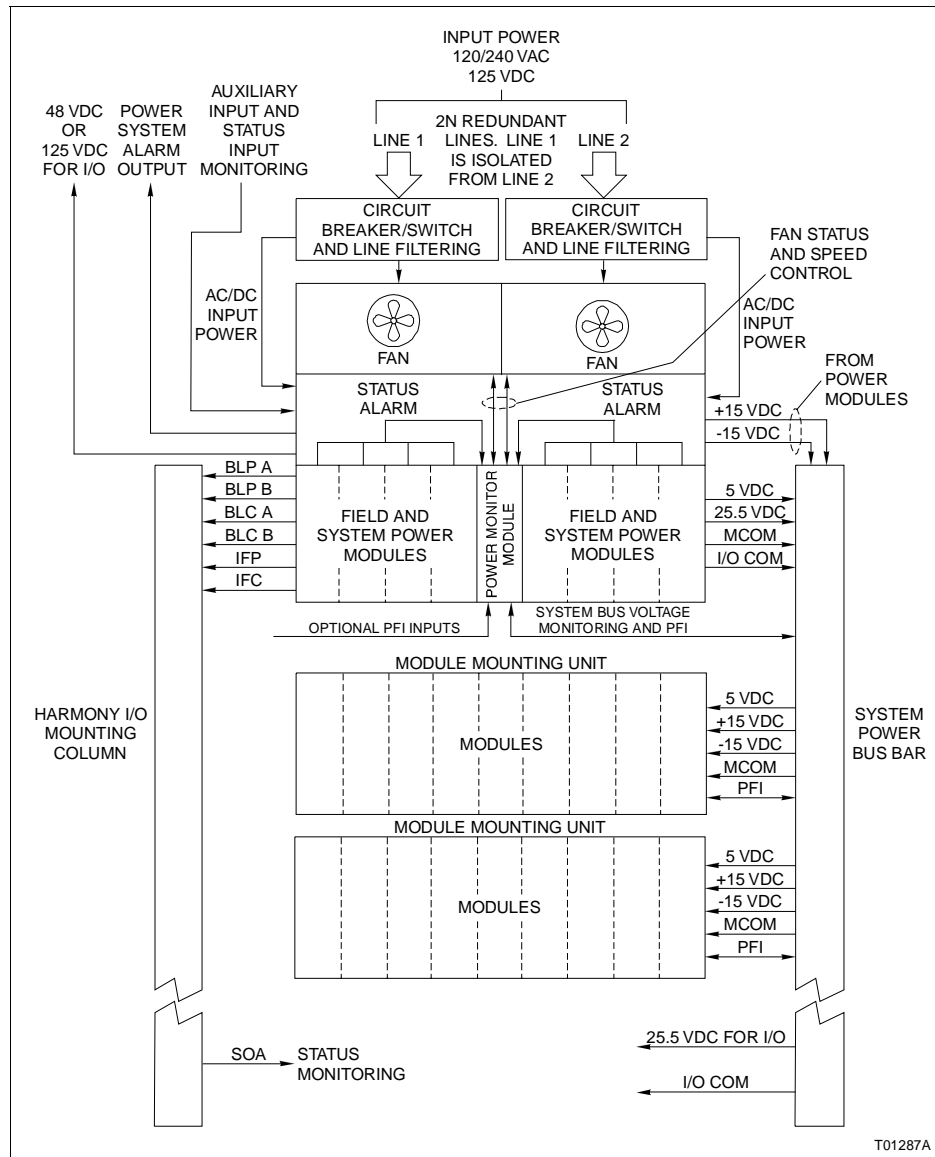

Figure 1. Modular Power System II Functional Diagram

The Modular Power System II consists of a power module chassis, fan chassis, power entry circuit breakers or switches, system fans, power monitor module, and power modules: System, Harmony, and field.

## I/O Block Operating Voltages

At the left side of Figure 1, the BLP A (block logic power) and BLP B lines shown entering the Harmony I/O mounting column are redundant 24 VDC outputs that provide the operating voltage for I/O blocks and Hnet repeaters. The IFP (internal field power) line shown entering the mounting column is 24 VDC I/O power for field devices. Additionally, the power system provides 48 VDC and 125 VDC field power.

## Rack I/O Module Operating Voltages

At the right side of Figure 1, the 5 VDC, 15 VDC, and -15 VDC lines shown entering the system power bus bar are the operating voltages for rack I/O devices. The 24 VDC (25.5 VDC actual voltage) line shown entering the system power bus bar is I/O power for field devices. Additionally, the power system provides 48 VDC and 125 VDC field power.

## System Power Module

---

The IPSYS01 System Power module is a rack mounted circuit board that supplies 5 VDC, 15 VDC, and -15 VDC system operating voltages to rack I/O devices and 24 VDC field I/O power to a cabinet. The system power module can accept 120 VAC, 240 VAC, or 125 VDC input power.

The AC inputs have active power factor correction to greater than 0.95. Current sharing circuitry enables the system power modules to equally share output current. The module monitors the DC-to-DC converters and power factor corrector and displays the status on five red/green faceplate LEDs. The system power module mounts in one power module chassis mounting slot.

## Field Power Modules

---

The IPFLD01 and IPFLD24 Field Power modules are similar to the system power module except that they output 24 VDC field I/O power only. The difference between the two power modules is that the IPFLD24 power module provides twice the output power of an IPFLD01 power module. The IPFLD48 and IPFLD125 Field Power modules output 48 VDC and 125 VDC field I/O power respectively.

The field power modules have the same power factor correction and internal monitoring circuitry. There are only two red/green LEDs on the field power modules: One for the DC-to-DC converter status and one for the power factor corrector status. The field power module mounts in one power module chassis mounting slot.

## Harmony Power Module

---

The IPBLC01 Harmony Power module is similar to the IPFLD24 field power module except that it supplies 24 VDC operating voltage to power Harmony I/O system devices such as I/O blocks and Hnet repeaters. The Harmony power module mounts in one power module chassis mounting slot.

---

## Power Monitor Module

---

The IPMON01 Power Monitor module checks power system status and the status inputs, which include:

- All system bus voltages (5, 15, -15 VDC), Harmony bus voltages (24 VDC A and B), I/O bus voltages (24 VDC, 48 VDC, and 125 VDC).
- Two selectable auxiliary inputs to monitor 24 VDC, 48 VDC, or 125 VDC external sources.
- Two cabinet temperature monitor inputs.
- One power fail interrupt (PFI) alarm that can be configured for latching or nonlatching operation.
- Two logic level status inputs. These contact logic inputs can be selected to accept normally open or normally closed contact inputs.
- Three isolated outputs for bus alarm, power alarm, and I/O alarm.
- One power system status output for use on the Symphony Control Net (Cnet) communication network.
- Two fan status inputs.
- One power supply status signal from each power module.
- Power monitor module internal circuitry status.

The power monitor module mounts in the center power module chassis slot.

The power monitor module faceplate has three red/green LEDs to indicate power monitor module status and AC or DC input power line status. Eight additional LEDs are used to show the state of status inputs. There are six test points that accept a voltmeter probe for checking 5, 15, -15, and 24 VDC bus voltages (two test points are system common and I/O common). The power fail interrupt reset pushbutton is used to reset a PFI signal when the PFI latched option is enabled.

---

## Power Module Chassis

---

The Modular Power System II supports two different power module chassis: IPCHS01 and IPCHS02. The IPCHS01 chassis supports Harmony rack I/O power connection only. It cannot be used for Harmony I/O block power connection. The IPCHS02 chassis supports both Harmony I/O block connection and Harmony rack I/O connection.

### IPCHS01 Chassis

The IPCHS01 Power Module Chassis provides power input connection, power output bus bars, and various terminals for status inputs and outputs. It provides mounting for up to eight power modules and one power monitor module. There are nine mounting slots total. The center slot is dedicated to the power monitor module. Four slots on each side of the power monitor module hold power modules and have isolated power inputs.

All the power module outputs share the same bus. System power for the cabinet is made available at bus bars on the power module chassis backplane and at terminal strips (for  $\pm 15$  VDC and 48/125 VDC). Cables connect the bus bars and  $\pm 15$  VDC terminals to the system power bus bar for distribution to the cabinet. The 48/125 VDC terminals are user outputs.

Power modules and the power monitor module can be removed from the power module chassis and replaced while the system is on-line. Only IPSYS01, IPFLD01, IPFLD24, IPFLD48, and IPFLD125 power modules and the IPMON01 power monitor module can be mounted in this power module chassis. The IPFLD48 and the IPFLD125 power modules cannot coexist in the same power module chassis.

## IPCHS02 Chassis

The IPCHS02 Power Module Chassis is identical to the IPCHS01 chassis except that it has additional bus bars for Harmony power (24 VDC) and ground and a power distribution assembly circuit board that attaches to the bus bars. The power distribution assembly supports redundant power distribution to Harmony I/O system devices. This circuit board has connectors installed for attaching the Harmony I/O power cables.

Power modules and the power monitor module can be removed from the power module chassis and replaced while the system is on-line. The IPSYS01, IPFLD01, IPFLD24, IPFLD48, and IPFLD125 power modules, the IPMON01 power monitor module, and additionally the IPBLC01 Harmony Power module can be mounted in this power module chassis. The IPFLD48 and the IPFLD125 power modules cannot coexist in the same power module chassis.

## Power Entry Circuit Breaker or Switch

The IPECB11 or IPECB13 Power Entry Circuit Breaker and IPESW11 or IPESW13 Power Entry Switch terminate the AC or DC power input lines and provide line filtering before feeding power to the power module chassis backplane. These devices mount on the back of the power fan chassis. One circuit breaker or switch is used on N, N+1, and N+x redundant systems (Fig. 2); two are used on 2N redundant systems (Fig. 3). The isolated inputs on 2N redundant systems allow for mixed power inputs (i.e., 125 VDC and 120/240 VAC) because two separate power entry circuit breakers or switches feed isolated power inputs to the power module chassis.

## Fan Chassis and System Fans

The IPFCH01 Power Fan Chassis mounts two system power fans. There are three types of fans in the Modular Power System II structure:

- IPFAN11 Power System Fan (120 VAC).
- IPFAN12 Power System Fan (240 VAC).
- IPFAN13 Power System Fan (125 VDC).

The fan chassis provides a power connection, and fan monitoring and control via a cable connection to the power module chassis backplane.

The power system fans mount side-by-side in the fan chassis. Hall effect sensors on the power system fans provide fan speed information to the power monitor module. Fan speed is controlled as a function of cabinet temperature. One fan is capable of cooling the cabinet and a failed fan can be replaced while the system is on-line.

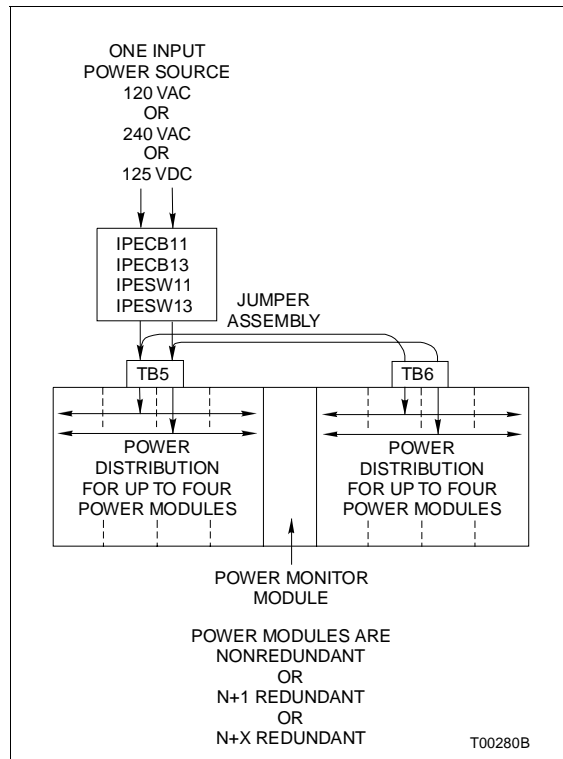

Figure 2. Input Power for N, N+1, and N+x Redundant Systems

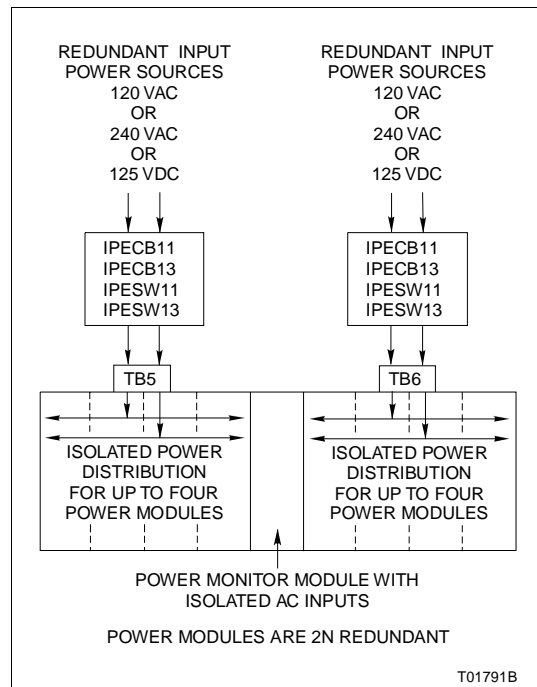

Figure 3. Input Power for 2N Redundant Systems



*Visit Elsag Bailey on the World Wide Web at <http://www.ebpa.com>*

---

Our worldwide staff of professionals is ready to meet *your* needs for process automation.  
For the location nearest you, please contact the appropriate regional office.

**AMERICAS**

29801 Euclid Avenue  
Wickliffe, Ohio USA 44092  
Telephone 1-440-585-8500  
Telefax 1-440-585-8756

**ASIA/PACIFIC**

539 Yishun Industrial Park A  
Singapore 768740  
Telephone 65-756-7655  
Telefax 65-753-6549

**GERMANY**

Industriestrasse 28  
D-65760 Eschborn  
Germany  
Telephone 49-6196-800-0  
Telefax 49-6196-800-1119

**EUROPE, AFRICA, MIDDLE EAST**

Via Puccini 2  
16154 Genoa, Italy  
Telephone 39-10-6584-943  
Telefax 39-10-6584-941